

Max. Bewegung ± 150 mm

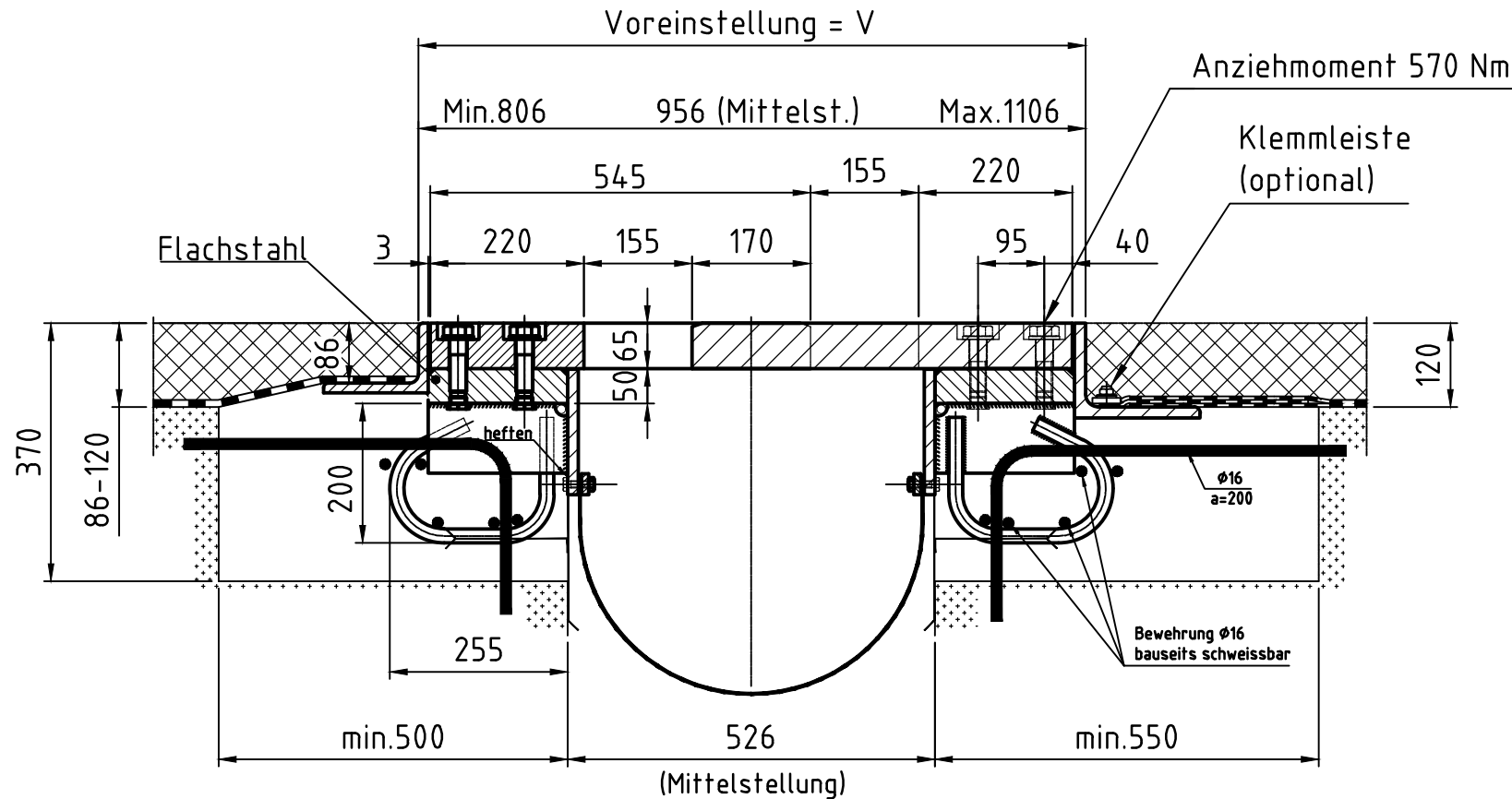

Widerlager
A-A 1:10

Tragwerk