

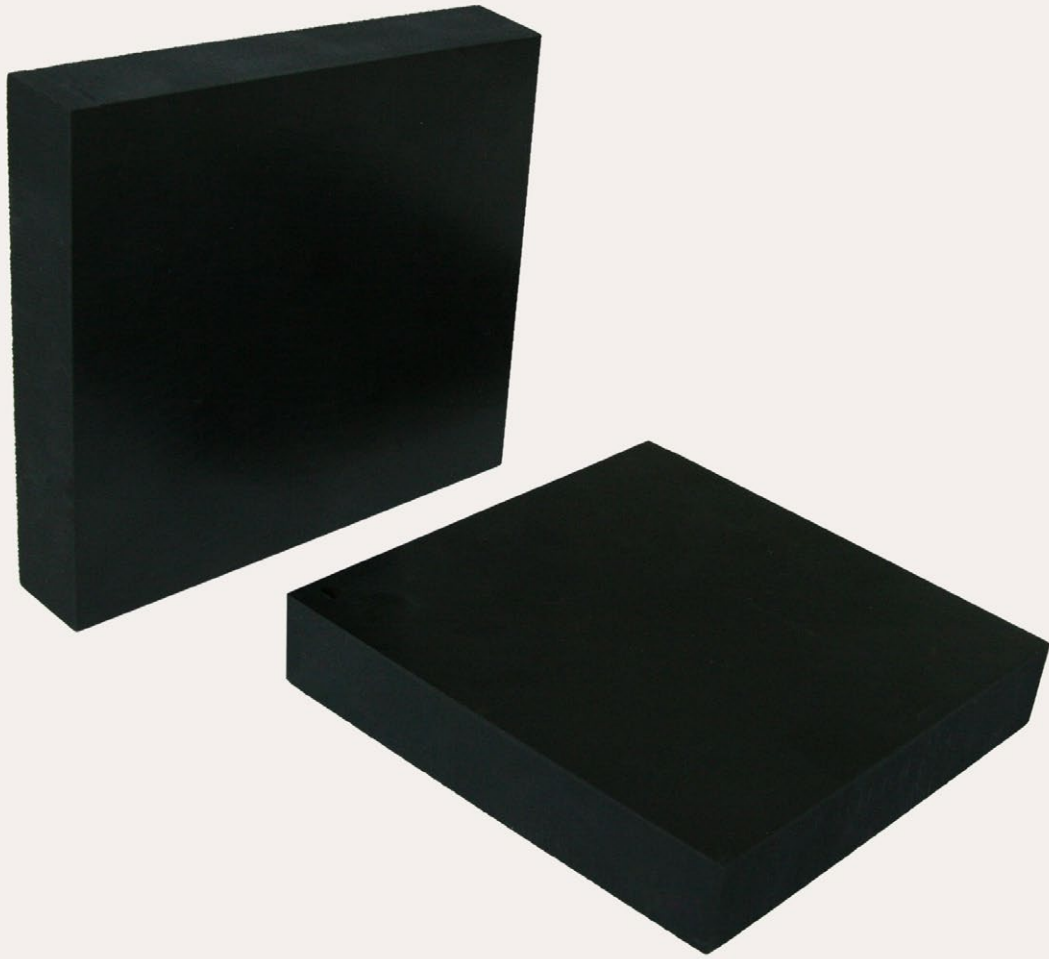

Structural bearings

Infrastructure | Buildings | Industrial structures

LASTO[®] – Elastomeric bearings



LASTO[®] BLOCK T

High-strength thermal isolation bearings

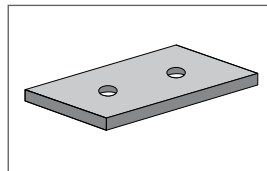
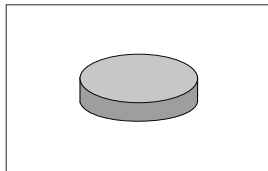
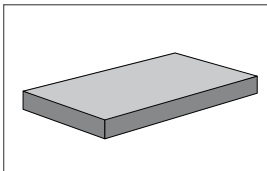

mageba



Application areas and important aspects

Application areas

LASTO®BLOCK T is a thermal isolation bearing of unreinforced high-strength elastomer, which can be used to transmit high pressure forces with little deformation while also resisting heat loss. Due to the use of high-quality elastomer compounds, LASTO®BLOCK T is very durable, requires no maintenance and can be used as a thermal isolator in endplate connections, beneath steel columns, beneath precast concrete elements or in wooden structures.

Permissible load depends on shape

As a result of the vertical pressure acting on the bearing, its sides bulge outwards (shear strain in the bearing). The extent to which this occurs depends on the ratio between the bearing's side lengths and its thickness. The higher this ratio (the higher the shape factor S), the stiffer the bearing's behaviour (see Figure 1). Depending on the friction between the bearing and the supporting surface, the bearing may also expand transversely (see Figure 1), so perimeter clearance should be checked.

... and supporting surface

The load bearing capacity of an elastomeric bearing is strongly dependent on the surfaces of the connecting structures. Against polished steel surfaces, the bearing displays lower stiffness and therefore

Application

- Thermal isolation while subjected to high pressures

Permissible pressure

- 52 N/mm² (at Serviceability Limit State)

Bearing shapes

- Any shape possible

Bearing type

- Elastomeric bearing, unreinforced

Material properties

- Material: NBR (nitrile rubber)
- Hardness: 90 ± 5 IRHD (M)
- Coefficient of thermal conductivity: 0.20 W/mK
- Temperature range: -20 bis + 65°C

lower load bearing capacity than against concrete. The design graphs thus show – to remain conservative – the permissible loads when placed against surfaces of polished steel.

Behaviour under permanent loads

Under the action of long-term loading, elastomers deform even without increasing loads. This so-called creep deformation continues for well over 100 days. This effect is already considered in the design diagrams.

Contents

Application areas and important considerations.....	2
Selection of design case.....	3
Definitions.....	4
Bearing design procedure.....	5
Design tables.....	7
Example: Endplate connection.....	9
Product range and installation advice.....	11
Text for tender documentation.....	12

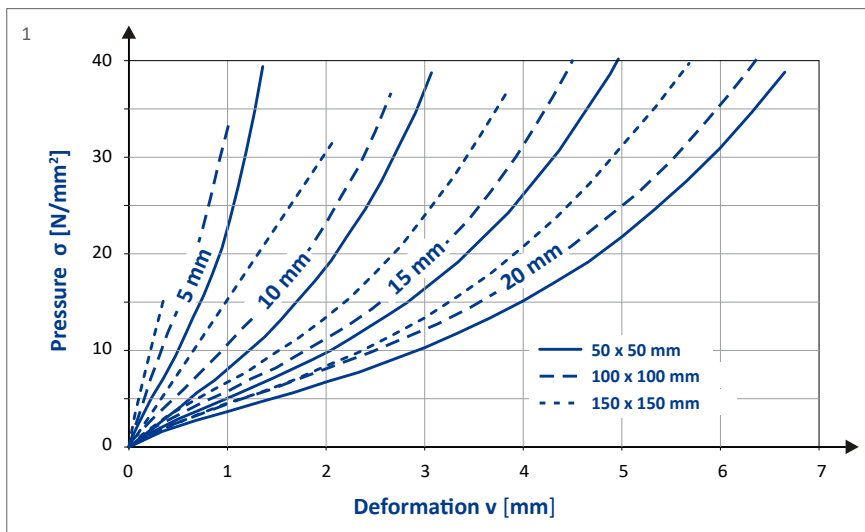

1 Deformation-Pressure graph from testing with various side lengths and thicknesses against polished steel plates (short-term loading without consideration of creep)

Cover picture:

Product: LASTO®BLOCK T
Elastomeric bearing

Selection of Design Case

Design Cases

Design Case ①

- Bearing for structural element
- Column footing

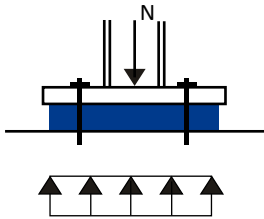

Design Case ②

- Column with eccentric normal force / rotation

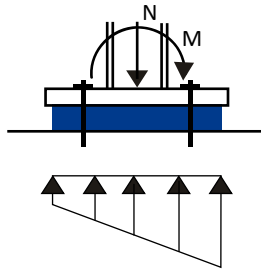

Design Case ③

- Endplate connection
- Clamped column

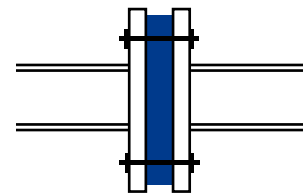

Various stress distributions are possible. See below for further sub-division of Design Case ③.

3a

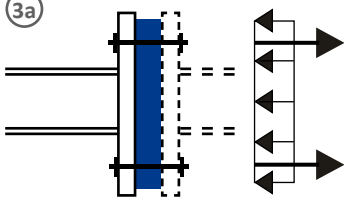

The pre-stress in the bolts is not cancelled out by normal force and moment. The pressure arises from the pre-stress in the bolts.

→ Design according to Design Case 1

3b

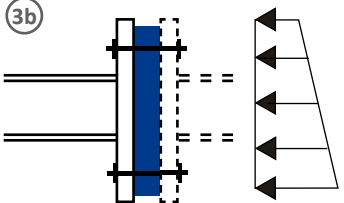

→ Design according to Design Case 2

3c

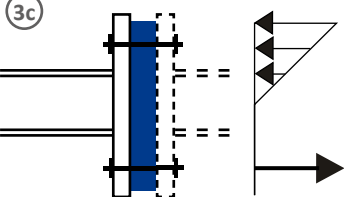

The pre-stress in all bolts is exceeded by normal force and moment. The pressure arises from normal force and moment only. The pre-stress in the bolts at one side is exceeded by normal force and moment. The pressure arises from normal force, moment and bolt pre-stress.

→ Design according to Design Case 3



Definitions

Explanation of variables

- a Length of elastomeric bearing (placed horizontally)
- b Width of elastomeric bearing (in endplate connection)
- h Height of elastomeric bearing (in endplate connection)
- t Thickness of elastomeric bearing
- e Abstand der Schrauben
- r Outward bulging of bearing
- S Shape factor of the bearing
- S_{red} Reduced shape factor (partial area)
- N Normal force
- M Moment
- F_v Pre-stress of a bolt (relax = reduced due to creep)
- $\sigma_{o/u}$ Stress at upper / lower edge
- $\bar{\sigma}$ Average stress of the partial area being designed
- σ_v Stress due to bolt pre-stress
- $\epsilon_{o/u}$ Compression strains due to pressure
- $\epsilon_{v,0}$ Compression strains due to pre-stressing
- $\bar{v}_{o/u}$ Average deformation of upper / lower partial area being designed
- \bar{v}_z Deformation of the bearing at its central axis
- α Rotation of the endplate connection
- $F_{s,o/s,u}$ Normal forces in the bolts in the upper / lower areas due to N, M and F_v

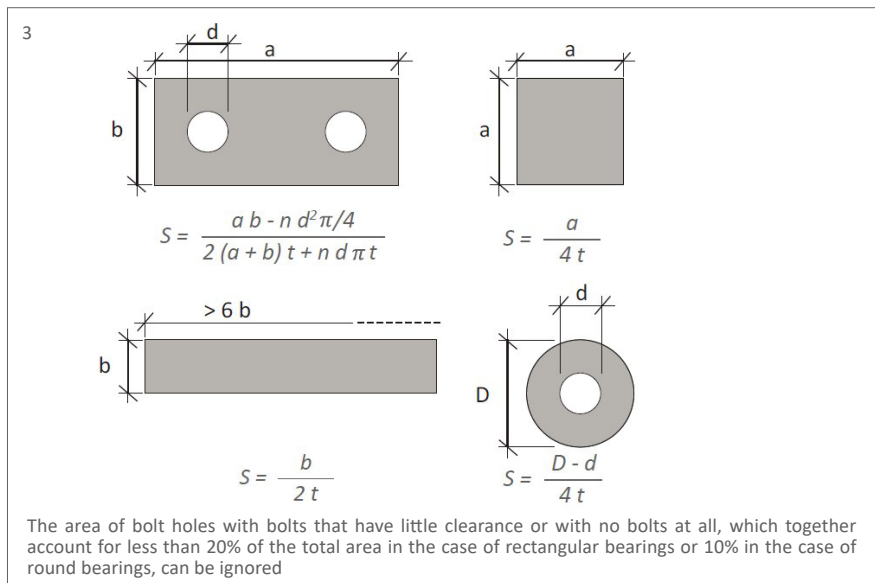
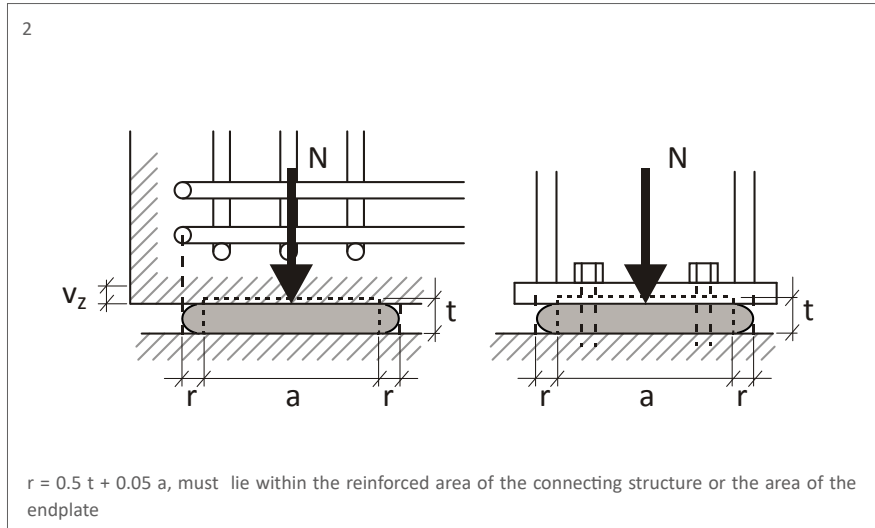

- 2 Schematic representation of bearing deformation; outward bulging
- 3 Shape factor S, depending on plan area and thickness t

Approaches to bearing design

Design Case 1

Approach I

- 1 Assume bearing thickness t and permissible deformation $v_{z,max}$
- 2 Calculate side lengths from Graphs 8 to 11 (depending on bearing thickness and vertical load)

Approach II

- 1 Assume side lengths a and b , bearing thickness t and permissible deformation $v_{z,max}$
- 2 Calculate the shape factor S (see Figure 3) and the pressure

$$\sigma_z = \frac{N}{a \cdot b} \quad [1]$$

- 3 Determine the compression strain ε_z (from Graph 12) for the selected bearing shape, depending on pressure and shape factor

$$v_z = t \cdot \varepsilon_z \quad [2]$$

- 4 Check if $v_{z,max} < v_z$

Approach III

- 1 Assume side lengths a and b , and bearing thickness t
- 2 Calculate pressure according to [1]
- 3 Determine the permissible pressure σ_{zul} with side lengths a and b and thickness t , using Table 1 on page 7
- 4 Check if $\sigma_z < \sigma_{zul}$

Design Case 2

- 1 Assume side lengths a and b , and bearing thickness t
- 2 Calculate the stresses $\sigma_{o,u}$ from normal force and moment

$$\sigma_{o,u} = \frac{N}{a \cdot b} \pm \frac{6 \cdot M}{b \cdot a^2} \quad [3]$$

- 3 If the surface stresses σ_o and σ_u do not deviate from each other by more than 10%, the design can be done in accordance with Design Case 1

- 4 Calculate the average pressure $\bar{\sigma}_o$ and $\bar{\sigma}_u$ in the outer thirds (see Figure 4)

$$\bar{\sigma}_o = \sigma_o - \frac{1}{6} (\sigma_o - \sigma_u) \leq 52 \text{ N/mm}^2 \quad [4]$$

$$\bar{\sigma}_u = \sigma_u - \frac{5}{6} (\sigma_o - \sigma_u) \leq 52 \text{ N/mm}^2 \quad [5]$$

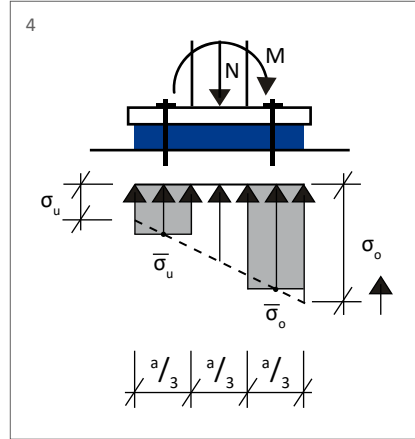

- 5 Determine reduced shape factor S_{red} for the upper and lower, or right and left stress areas

$$S_{red} = \frac{b \cdot h}{6 \cdot (b + \frac{h}{3})} \cdot t \text{ resp. } \frac{a \cdot b}{6 \cdot (b + \frac{a}{3})} \cdot t \quad [6]$$

- 6 Determine the average compression strain $\bar{\varepsilon}_o$ and $\bar{\varepsilon}_u$ in the stress areas from the average stresses $\bar{\sigma}_o$ and $\bar{\sigma}_u$ and the shape factor S_{red} in accordance with Graph 12

- 7 Check if $\bar{\varepsilon}_{o,u} \leq \varepsilon_{zul} = 30\%$

- 8 Optionally, the average vertical deformation v_z and the rotation α_a can now be determined with the help of Steps 9 and 10

- 9 Determine average vertical deformation using

$$\bar{v}_o = \bar{\varepsilon}_o \cdot t \quad [7]$$

$$\bar{v}_u = \bar{\varepsilon}_u \cdot t \quad [7]$$

$$v_z = \frac{\bar{v}_o + \bar{v}_u}{2} \quad [8]$$

- 10 Determine rotation α_a using

$$\alpha = 3 \cdot \frac{(\bar{v}_o - \bar{v}_u)}{2 \cdot a} \quad [10]$$

Design Case 3

Due to the relaxation of the elastomer (creep strain $\phi = 18\%$), some of the pre-stressing force of the bolts is lost. This must be considered in the design. The pre-stressing forces and bolts must be arranged symmetrically.

- 1 Assume bearing thickness t , side lengths b and h , bolt spacing e and pre-stressing force F_v for each bolt
- 2 Calculate the stress immediately after pre-stressing with force F_v in n bolts:

$$\sigma_{v,0} = \frac{n \cdot F_v}{b \cdot h} \quad [11]$$

Note: All bolts are to be retightened after 10 minutes to compensate for the loss of pre-stress from short-term creep.

- 3 Calculate the shape factor for the whole bearing surface:

$$S = \frac{a \cdot b}{2 \cdot (a + b) \cdot t} \quad [12]$$

- 4 Determine the compression strain ε'_v of the bearing due to pre-stress with the help of Graph 12

- 5 Determine the elastic part of the compression strain $\varepsilon_{v,0}$ considering creep:

$$\varepsilon_{v,0} = \frac{\varepsilon'_v}{1 + \phi} = \frac{\varepsilon'_v}{1.18} \quad [13]$$

- 6 Determine the relaxation-reduced pressure from pre-stress, $\sigma_{v,relax}$ for compression strain $\varepsilon_{v,0}$ using Graph 12

- 7 Calculate the reduced pre-stressing force $F_{v,relax}$:

$$F_{v,relax} = \frac{1}{n} \cdot \sigma_{v,relax} \cdot a \cdot b \quad [14]$$

Circumstance 1: Pre-stress is not lost (not cancelled out by other effects)

- 8 Calculate bolt forces $F_{s,o}$ (upper) and $F_{s,u}$ (lower), to establish whether or not the pre-stress is cancelled out:

$$F_{s,o} = \frac{-N}{n} - \frac{2 \cdot M}{n \cdot e} + F_{v,relax} \quad [15]$$

$$F_{s,u} = \frac{-N}{n} + \frac{2 \cdot M}{n \cdot e} + F_{v,relax} \quad [16]$$

(continued on next page)



Approaches to bearing design

Design Case 3 (continued)

9 If $F_{s,o} > 0$ and $F_{s,u} > 0$, then the pre-stress is not cancelled out.

Rotation $\alpha = 0$

Deformation $v_x = \epsilon_v \cdot t$

Bearing pressure $\sigma_o = \sigma_u = \sigma_{v,relax}$

See Figure 5

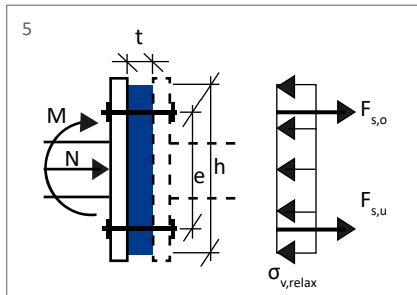

Circumstance 2: Pre-stress is lost on both sides (cancelled out by other effects on both sides)

10 Calculate the stresses should the bolts be removed:

$$\sigma_o = \frac{N}{b \cdot h} + \frac{6 \cdot M}{b \cdot h^2} \quad [17]$$

$$\sigma_u = \frac{N}{b \cdot h} - \frac{6 \cdot M}{b \cdot h^2} \quad [18]$$

$$\sigma_{s,u} = \sigma_o + \frac{\sigma_u - \sigma_o}{a} \cdot \frac{a + e}{2} \quad [19]$$

11 If $\sigma_{s,u} < \sigma_{v,relax}$ then the pre-stress in all bolts is cancelled out. The design is to be done in accordance with Design Case 2. Otherwise, proceed to Circumstance 3:

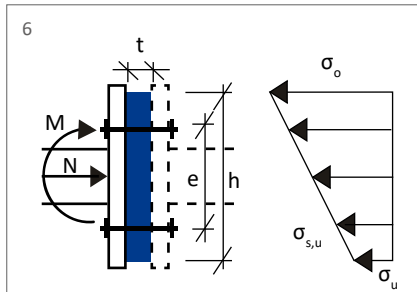

Circumstance 3: Pre-stress is lost on upper side (cancelled out by other effects)

If the pre-stress in the bolts is only cancelled out at one side, the design is to be done as follows:

Calculate the stresses and the bolt forces should the upper bolts be removed (positive bending moment = tension on lower side):

$$\sigma_o = \frac{N + \frac{2 \cdot M}{e}}{b \cdot \frac{a + e}{4} \left(1 + \frac{2 \cdot a - e}{3 \cdot e}\right)} \quad [20]$$

$$\sigma_u = \sigma_o - \frac{2 \cdot a}{a + e} (\sigma_o - \sigma_{v,relax}) \quad [21]$$

$$F_{s,u} = \frac{2}{n} \left(-N + b \cdot a \cdot \frac{\sigma_o + \sigma_u}{2}\right) \quad [22]$$

Check stresses using equations [6] and [7]

The provided formulae for Circumstance 3 represent a simplification of the equations. The stresses at the upper bearing edge are slightly overestimated. At relatively low bending moments the bolt forces are overestimated by up to about 25 %.

Design of the bearing

The bearing is designed using the above calculated stresses σ_o and σ_u . In the case of uneven pressure due to the effect of moment, the bearing part with greater pressure is used for the design.

12 If the ratio $\sigma_o/\sigma_u < 1.1$, then the pressure distribution should be considered even. Determine compression strain $\epsilon_u = \epsilon_o$ with stress σ_o using Graph 12

If the compression strain $\epsilon_o > 30\%$, the bearing is overloaded.

13 If the pressure distribution is uneven, with $\sigma_o/\sigma_u > 1.1$, then only 1/3 of the bearing at each side must be considered in the design.

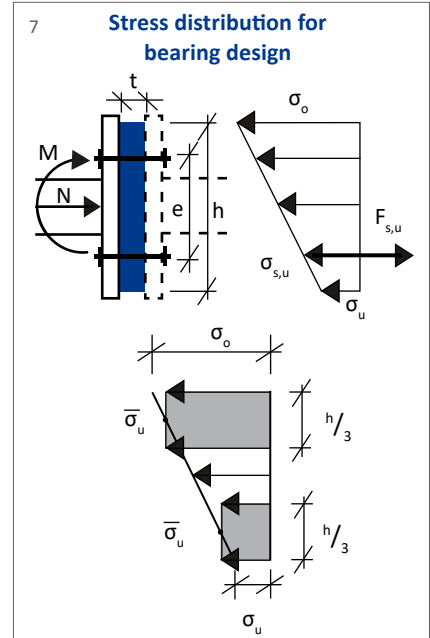

14 The relevant compression strains $\bar{\epsilon}_o$ and $\bar{\epsilon}_u$ are determined from $\bar{\sigma}_o$ and $\bar{\sigma}_u$ using Graph 12, with the shape factor S_{red} calculated according to [8].

If the compression strain $\bar{\epsilon}_o > 30\%$, then the bearing is overloaded.

15 The relevant deformations of the partial areas are calculated using [7] and [8]:

16 The rotation α of the connecting surface, in the case of bearings for which the pre-stress of all bolts is cancelled out, is calculated using [10].

In the case of bearings for which the pre-stress of the bolts is only cancelled out at one side, the rotation is calculated using:

$$\alpha = \frac{6 (\bar{v}_o - \epsilon_{v,o} \cdot t)}{2h + 3e} \quad [23]$$

Attention: If, in addition to bending moment and normal force, a transverse force must also be transmitted by the bolts, then the bolts can be designed using the following interaction formula.

$$\left[\frac{N_d}{N_{R,d}}\right]^2 + \left[\frac{V_{a,d}}{V_{a,R,d}}\right]^2 + \frac{M}{M_{R,d}} \leq 1 \quad [24]$$

Design tables

Table 1: Maximum permissible pressure in N/mm², depending on side lengths a, b and thickness t

Thicknesses [mm]					Side length a [mm]															
					5	20	25	30	40	50	60	70	80	90	100	120	140	165	200	250
5	10	15	20	5	40	50	60	80	100	120	140	160	180	200	240	280	330	400	500	
				10	60	75	90	120	150	180	210	240	270	300	360	420	495	600	750	
Side length b [mm]	5	10	15	20	80	100	120	160	200	240	280	320	360	400	480	560	660	800	1000	
	20	24	24	25	26	26	27	27	27	27	27	27	28	28	28	28	28	28	29	
	25	24	25	26	27	28	28	28	29	29	29	29	29	30	30	30	30	31	31	
	30	25	26	27	28	29	29	30	30	31	31	31	31	32	32	32	32	33	33	
	40	26	27	28	29	31	32	32	33	34	34	34	34	35	36	36	36	37	37	
	50	26	28	29	31	32	33	34	35	36	37	38	38	39	39	40	40	40	41	
	60	27	28	29	32	33	35	36	37	38	39	40	41	42	43	43	44	44	45	
	70	27	28	30	32	34	36	38	39	40	41	43	44	45	46	46	47	47	49	
	80	27	29	30	33	35	37	39	40	42	43	45	46	47	49	51	52	52	52	
	90	27	29	31	34	36	38	40	42	43	45	47	48	49	51	52	52	52	52	
	100	28	29	31	34	37	39	41	43	45	46	48	51	52	52	52	52	52	52	
	120	28	30	32	35	38	40	43	45	47	48	52	52	52	52	52	52	52	52	
	140	28	30	32	36	39	42	44	46	49	51	52	52	52	52	52	52	52	52	
	165	28	30	32	36	40	43	46	48	51	52	52	52	52	52	52	52	52	52	
	200	28	31	33	37	40	44	47	50	52	52	52	52	52	52	52	52	52	52	
	250	29	31	33	37	41	45	49	52	52	52	52	52	52	52	52	52	52	52	

(e.g. bearing 80 x 200 x 10 mm³: $\sigma_{zul} = 34 \text{ N/mm}^2$)

Determination of side length of a square bearing on the basis of vertical load and permissible deformation v_z

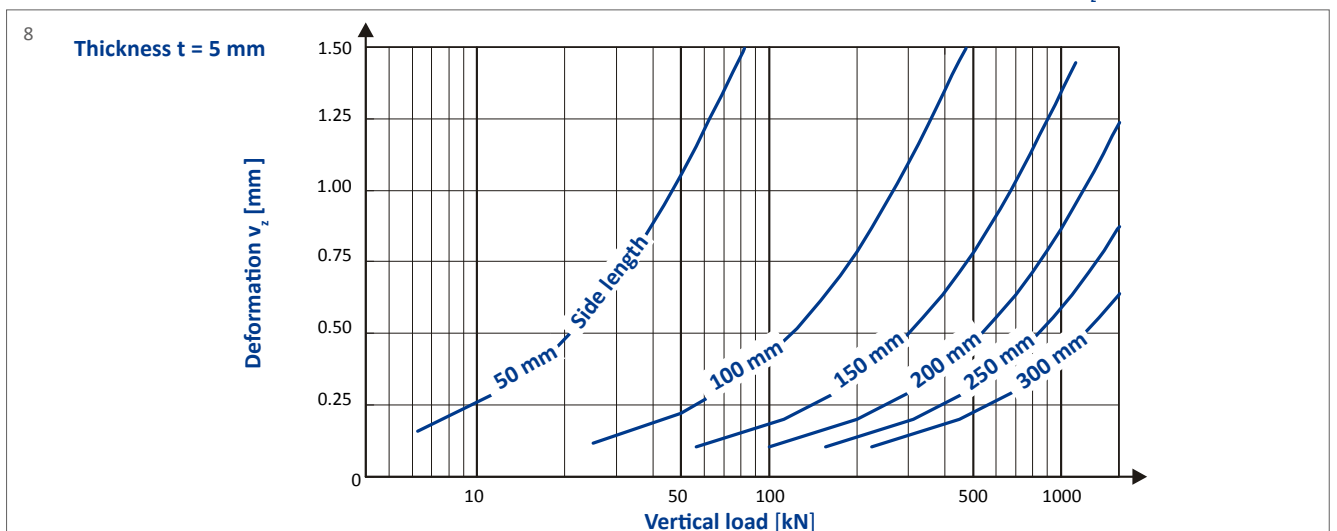



Design tables

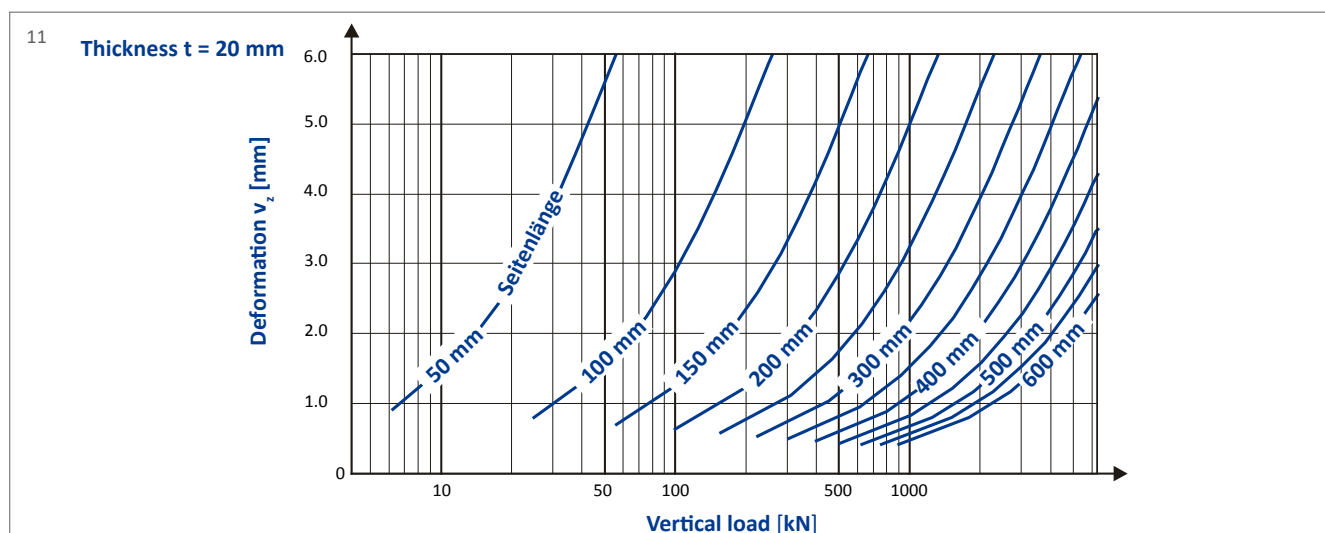
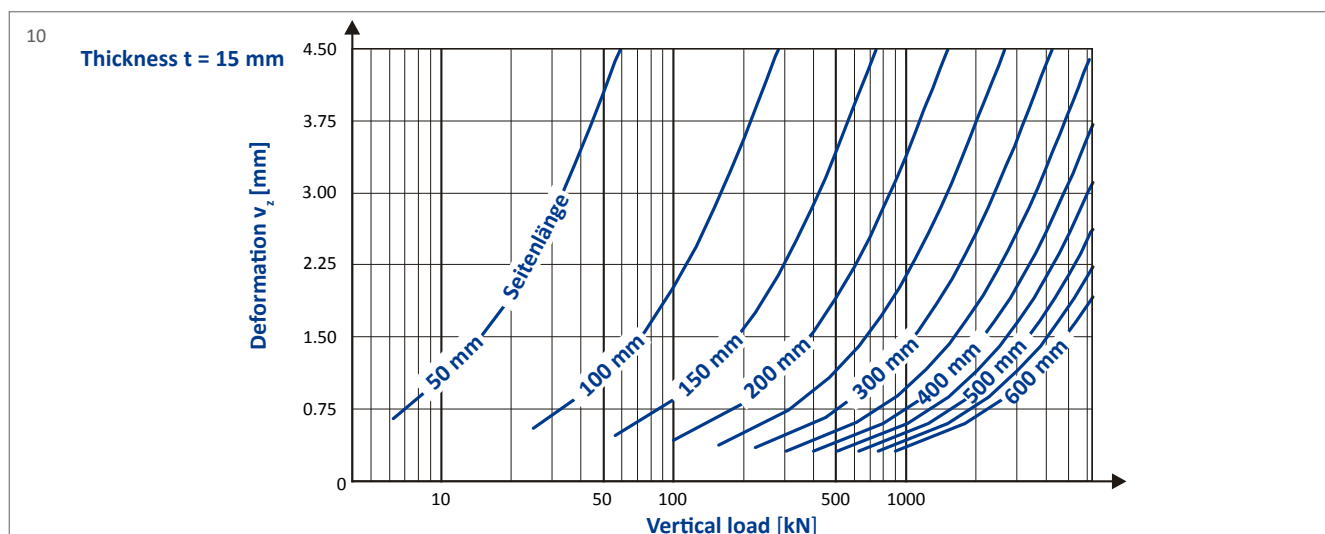
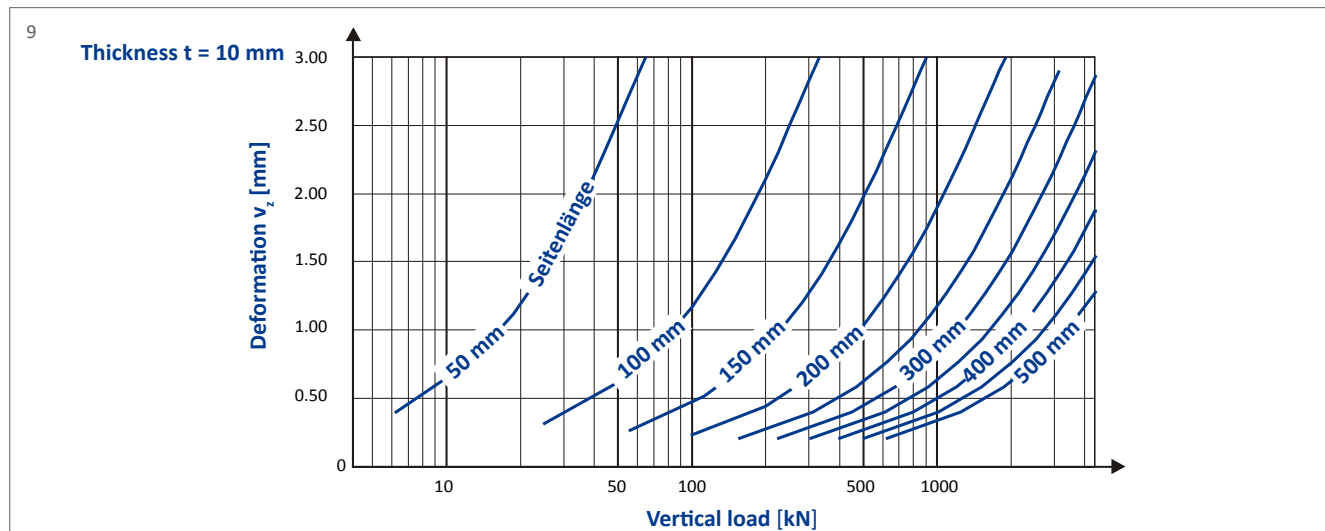

Example: Endplate connection

Challenge:

Forces and moments:

$$M = 65 \text{ kNm}$$

$N = 200 \text{ kN}$ (Pressure force in beam is positive)

$F_v = 110 \text{ kN}$ (Bolt tension force is positive)

Dimensions:

$$b = 160 \text{ mm}; h = 320 \text{ mm}; e = 280 \text{ mm}$$

$$t = 15 \text{ mm}$$

$$n = 6$$

$r = 25 \text{ mm}$ (>23.5 mm i.e. adequate according to Figure 2)

Solution:

All pressure stresses in the bearing are positive:

$$\sigma_{v,o} = 12.9 \text{ N/mm}^2 \quad \text{according to [11]}$$

$$S = 3.56 \quad \text{according to [12]}$$

Compression strain ϵ_v due to pre-stressing, from Graph 12:

$$\epsilon_v = 0,122$$

$$\epsilon_{v,o} = 0,103 \quad \text{according to [13]}$$

$$\sigma_{v,relax} = 10 \text{ N/mm}^2 \text{ from Graph 12}$$

$$F_{v,relax} = 85.3 \text{ kN} \quad \text{according to [14]}$$

$$F_{s,o} = \frac{-200 \text{ kN}}{6} - \frac{2 \cdot 65 \text{ kNm}}{6 \cdot 280 \text{ mm}} + 85.3 \text{ kN} = -25.4 \text{ kN} \quad \text{according to [15]}$$

($F_{s,o} < 0$, i.e. pre-stressing force can be cancelled out)

$$F_{s,u} = 129.4 \text{ kN}$$

Bolt is loaded in tension, i.e. Design Case 3 applies

$$\sigma_o = 19.4 \text{ N/mm}^2 \quad \text{according to [20]}$$

$$\sigma_u = 9.4 \text{ N/mm}^2 \quad \text{according to [21]}$$

$$F_{s,u} = 178.7 \text{ kN (e.g. M20, 10.9)} \quad \text{according to [22]}$$

$$\bar{\sigma}_o = 17.7 \text{ N/mm}^2 \quad \text{according to [4]}$$

$$S_{red} = 2.13 \quad \text{according to [6]}$$

From Graph 12:

$$\bar{\epsilon}_o = 0.204 < 30 \%, \text{ i.e. loading permissible}$$

$$\bar{v}_o = 3.06 \text{ mm} \quad \text{according to [7]}$$

$$\alpha = 0.61 \% \quad \text{according to [23]}$$

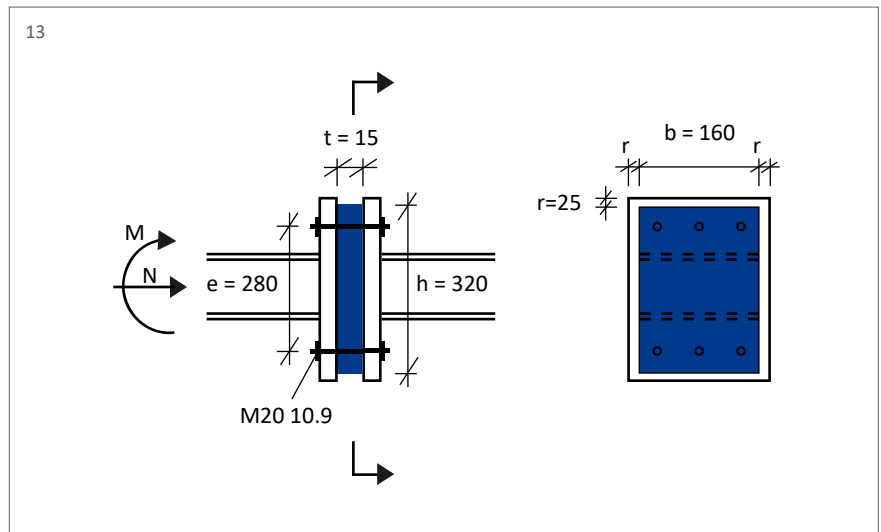
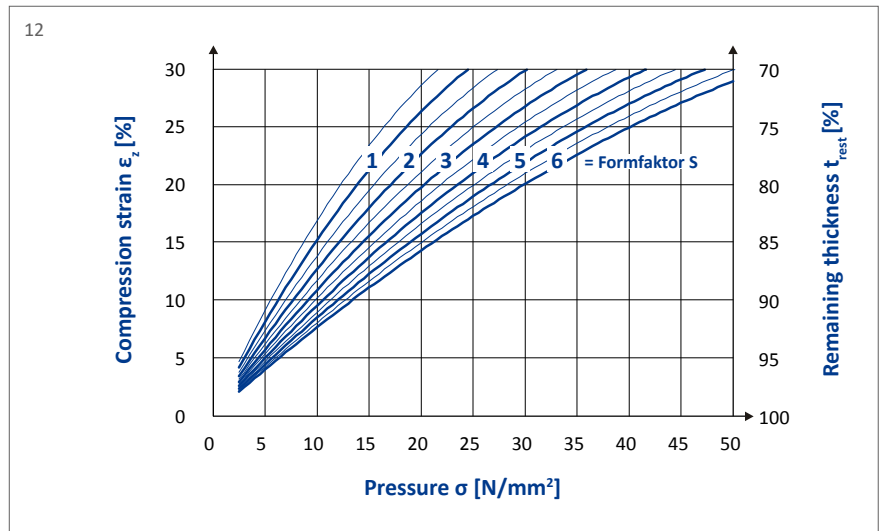

- 12 Dependence of compression (including creep) on pressure and shape factor
- 13 Drawing of an endplate connection



RESTON®POT Pot bearings

In 2007, mageba supplied the world's largest pot bearing with a load capacity of 210,000 kN for the Convention Center in Hong Kong.



RESTON®SPHERICAL Spherical bearings

Product range and installation guidelines

Product range

Types	Bearing height H [mm]	max. dimensions L x B [mm]	Delivery form
LASTO®BLOCK T 05	5	1000 x 1000	In sheets or cut to customer requirements, with holes if required
LASTO®BLOCK T 10	10	1000 x 1000	
LASTO®BLOCK T 15	15	1000 x 1000	
LASTO®BLOCK T 20	20	1000 x 1000	

Installation guidelines

When placed against concrete or mortar, it must be ensured that the connecting structure has adequate strength and a flat surface without ridges, burrs or large recesses. It must also be ensured that the bearing surfaces are clean and grease-free.



Structural bearings

Tender texts

Tender texts

Supply and installation of high-capacity, unreinforced thermal isolation bearings

Product: LASTO®BLOCK T

The permissible loading depends on the bearing geometry and is limited to max. 52 N/mm².

Proven remaining bearing thickness under a permanent load of duration 100 days to be min. 60% of nominal thickness.

Maximum allowed rotation capacity $\alpha = \dots \%$

Bearing thickness: mm

Dimensions (L x B) : mm x mm

Including creation of a flat load-bearing surface.

Units: Pieces.

Supplier:

mageba sa

Glasi Haus A, Trafostrasse 1

8180 Bülach

Switzerland

Tel.: +41-44-872 40 50

Email: buildings.ch@mageba-group.com

www.mageba-group.com

Project references



Amiens, FR



Municipal library of Stuttgart, DE



Convention Center, HK



Shopping Centre, CH



Hurghada Airport, EG



Stade de Suisse, CH

Product groups (building construction)



Structural bearings



Vibration isolation

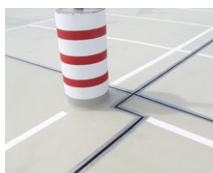

Expansion joints



Special products

mageba
mageba-group.com

engineering connections®