

Typical example of corrosion protection for expansion joint type RSFD-B:
Corrosion protection according to DIN EN ISO 12944, system-Nr. A4.15 (zinc metal spray galvanising for the first layer system-Nr.A8.01). Corrosivity category: C4, expected durability H (High). Sandblasting using only angular mineral blasting material e.g. corund, maximum size 20 to 24. Target surface roughness: Rz min. 60 µm, alternatively min. Elcometer-roughness 2.

Substructure		Corrosion protection	
1	1. SANDBLASTING		Sa 2½
	2. ZINC DUST EP PRIMER, 2-PACK		80 µm
	3. MIO EP, 2-PACK (ca. RAL 7035) (Silver grey)		80 µm
	4. PUR, 2-PACK (RAL 7042)(Traffic grey A)		80 µm
Total thickness (Target thickness)			240 µm
or			
2	1. SANDBLASTING		Sa 3
	2. ZINC METAL SPRAY GALVANISING		80 µm
	3. MIO EP, 2-PACK (ca. RAL 7035) (Silver grey)		80 µm
	4. PUR, 2-PACK (RAL 7042)(Traffic grey A)		80 µm
Total thickness (Target thickness)			240 µm
This coating has to be used for all steel parts but not for areas that are going to be concreted, with 30mm overlap of full corrosion protection and concrete; not for components which are made of stainless steel or hot dip galvanised.			
Top view		Bottom view	
3	1. SANDBLASTING		Sa 3
	2. ALKALISILICATE/ZINC DUST (685.03 grau)		40 µm
	3. MIO EP, 2-PACK (ca. RAL 7035) (Silver grey)		60 µm
	4. PUR, 2-PACK (ca. RAL 7001) (Light grey)		60 µm
	5. PUR, 2-PACK (RAL 7042)(Traffic grey A)		80 µm
Total thickness (Target thickness)			240 µm
Anti-slip coating			
1. SANDBLASTING			Sa 3
2. ALKALISILICATE/ZINC DUST (685.03 grau)			40 µm
Anti-slip-coating			
Total thickness (Target thickness)			40 µm

General Notes:

- Static calculation of load bearing parts (finger plates, bolts, substructure, anchorage) in accordance with RVS 15.45 and AASHTO.
- The position of the downsput in the drainage channel can be freely chosen.
- Diamond pattern on the surface is optional.
- All dimensions are in millimeters.

Movement capacities

longitudinal	transverse	vertical
250 mm	±2 mm	±5 mm

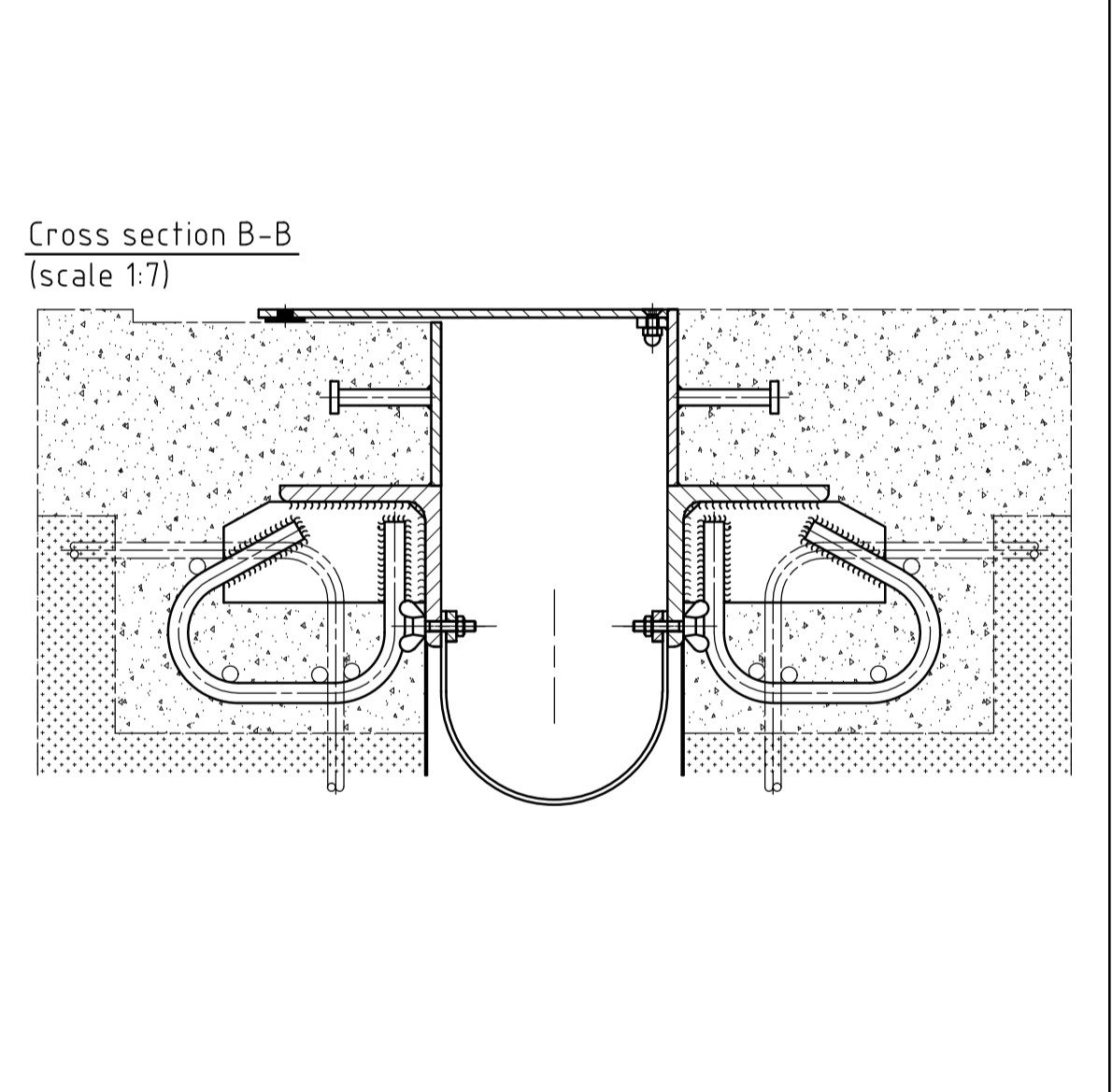
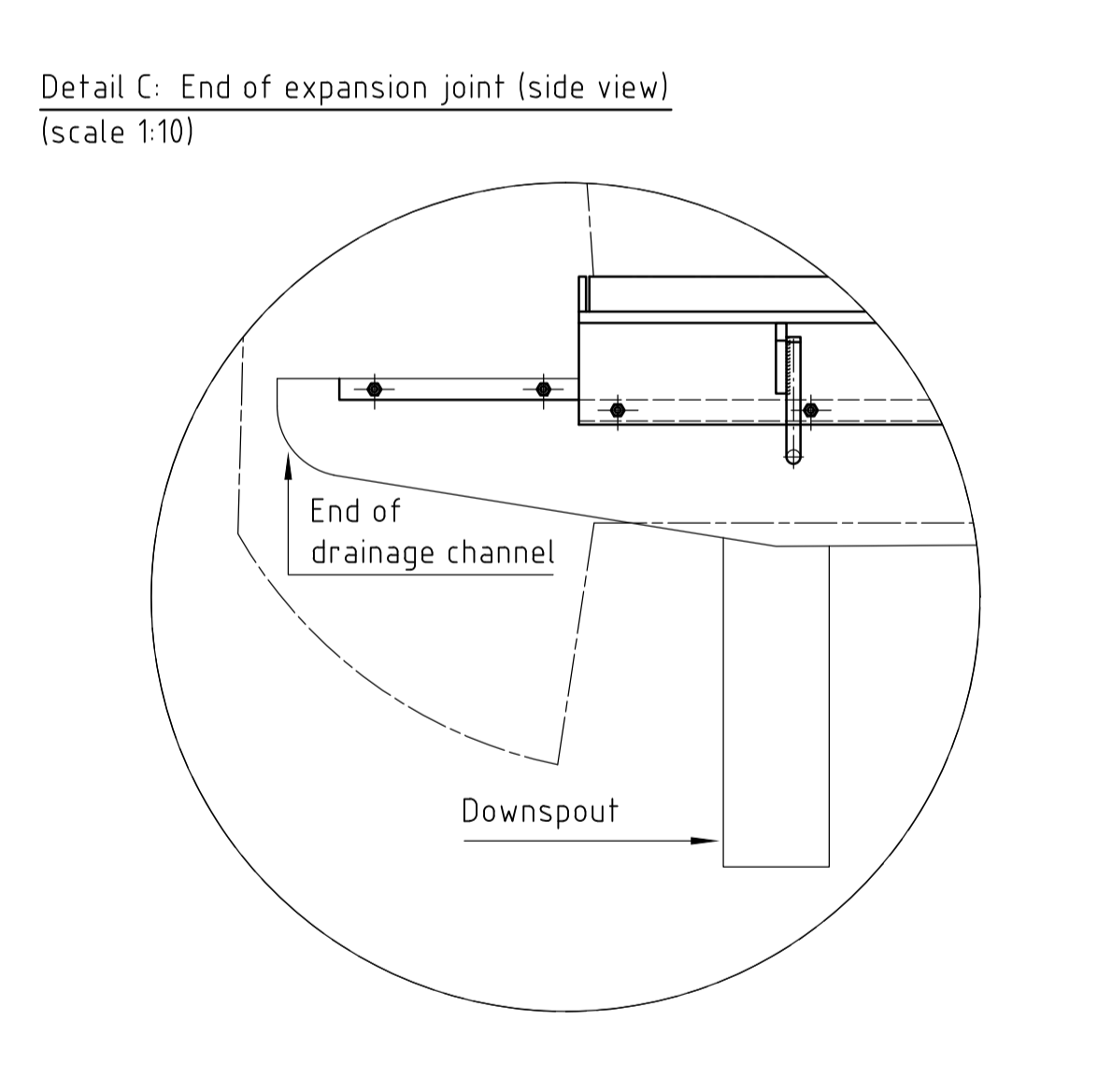
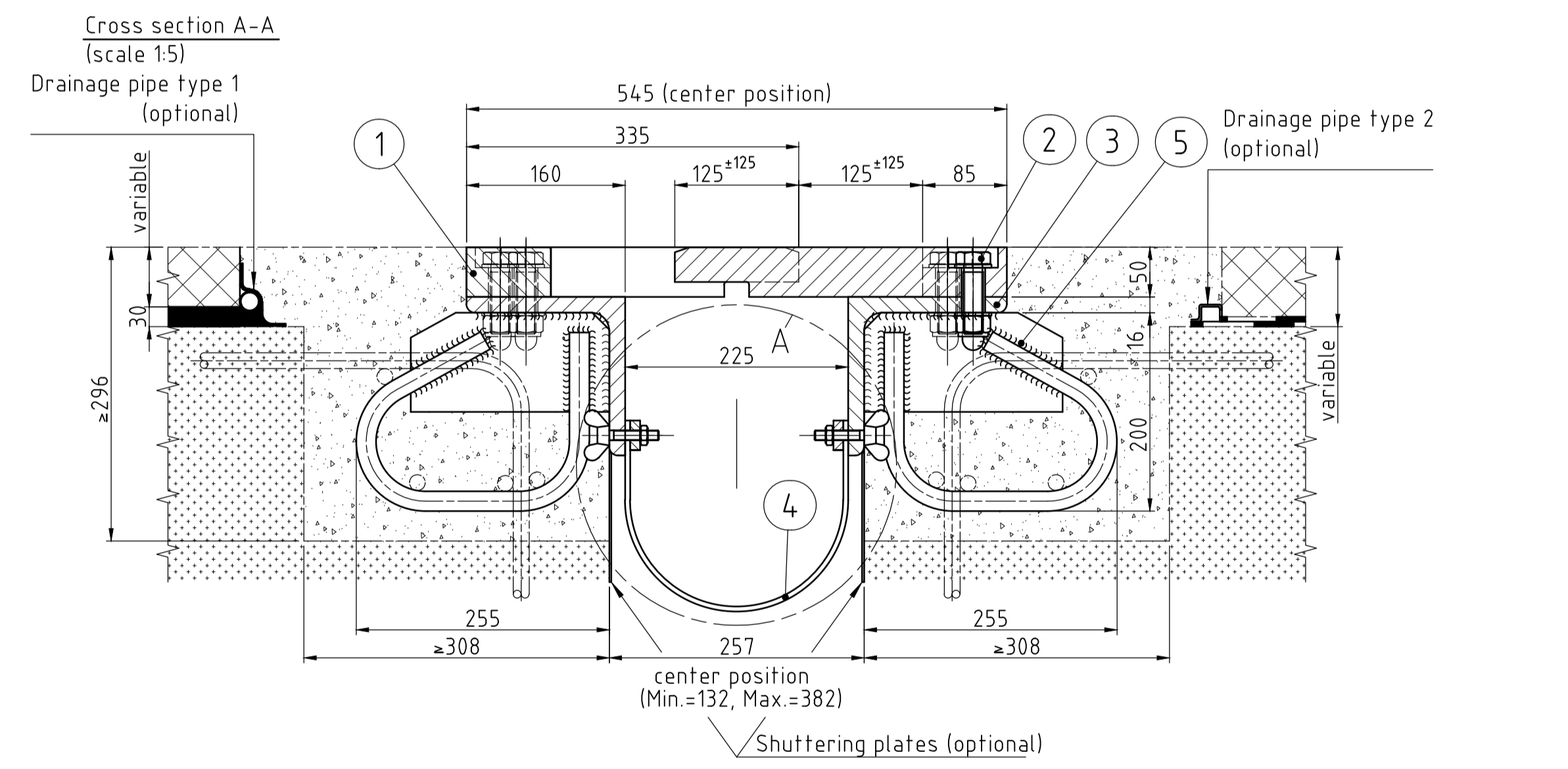

Installation Procedure:

- Preparation of the Joint Gap (recess):
The recess must be dimensioned to suit the size and shape of the expansion joint.
- Lifting in of joint:
The prepared joint is carefully lifted into position, and temporarily supported.
- Adjustment and fixing of the expansion joint:
In the near vicinity of the recess, level reference points should be marked (to be arranged by the Contractor/Engineer). In this way the exact height adjustment of the expansion joint on the structure can be guaranteed.
Then the expansion joint is adjusted exactly in longitudinal and transverse direction and in height. It should also be ensured, that the expansion joint is installed with the same longitudinal incline as the bridge surface.
- Fixing of the first side:
A provisional connection between the anchor loops of the expansion joint and the bridge reinforcement is made by welding.
Then the reinforcement is placed and welded to the joint until all parts are firmly connected. The expansion joint is sufficiently secured when no noticeable vibrations occur when the joint is shaken or walked upon.
- Fixing of the second side:
First the presetting of the joint has to be checked for the last time and adjusted if necessary. The procedure is similar to that at the first side. The expansion joint is fixed (temporarily) as quickly as possible to the bridge reinforcement.
Attention: Directly after the provisional fixing of the second side, the bolts of the installation beams are loosened. This allows the expansion joint to freely follow the movements of the structure.
- Shuttering plates:
The shuttering plates are then installed in such a manner that they seal the joint gap properly.
- Concreting:
Before pouring the concrete, the joint should be covered to protect it from dirt, and the gap must be thoroughly watered to ensure it does not take too much water from the fresh concrete.
The applied concrete is vibrated. When completed, the concrete must be flush with the top of the joint.

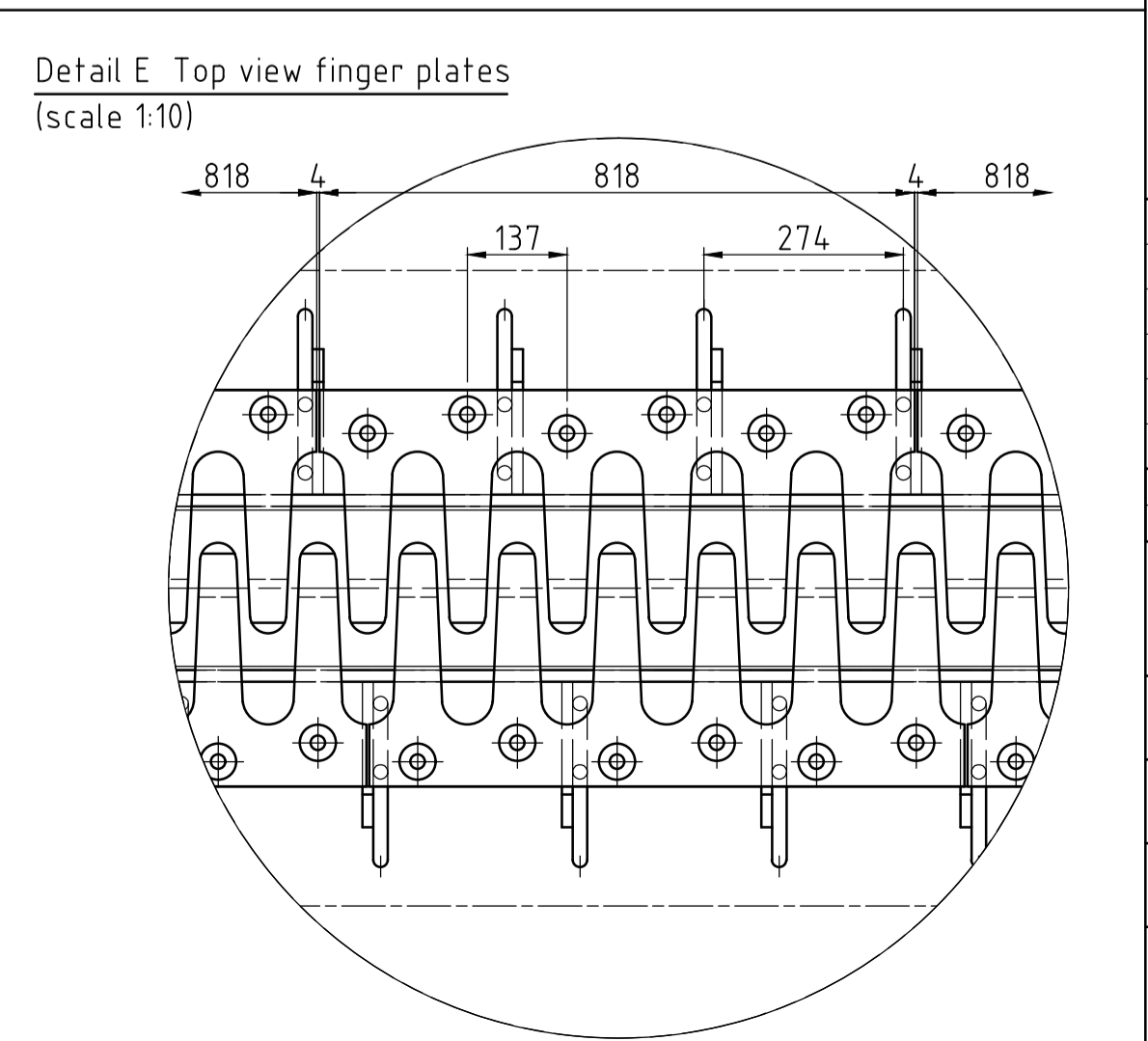
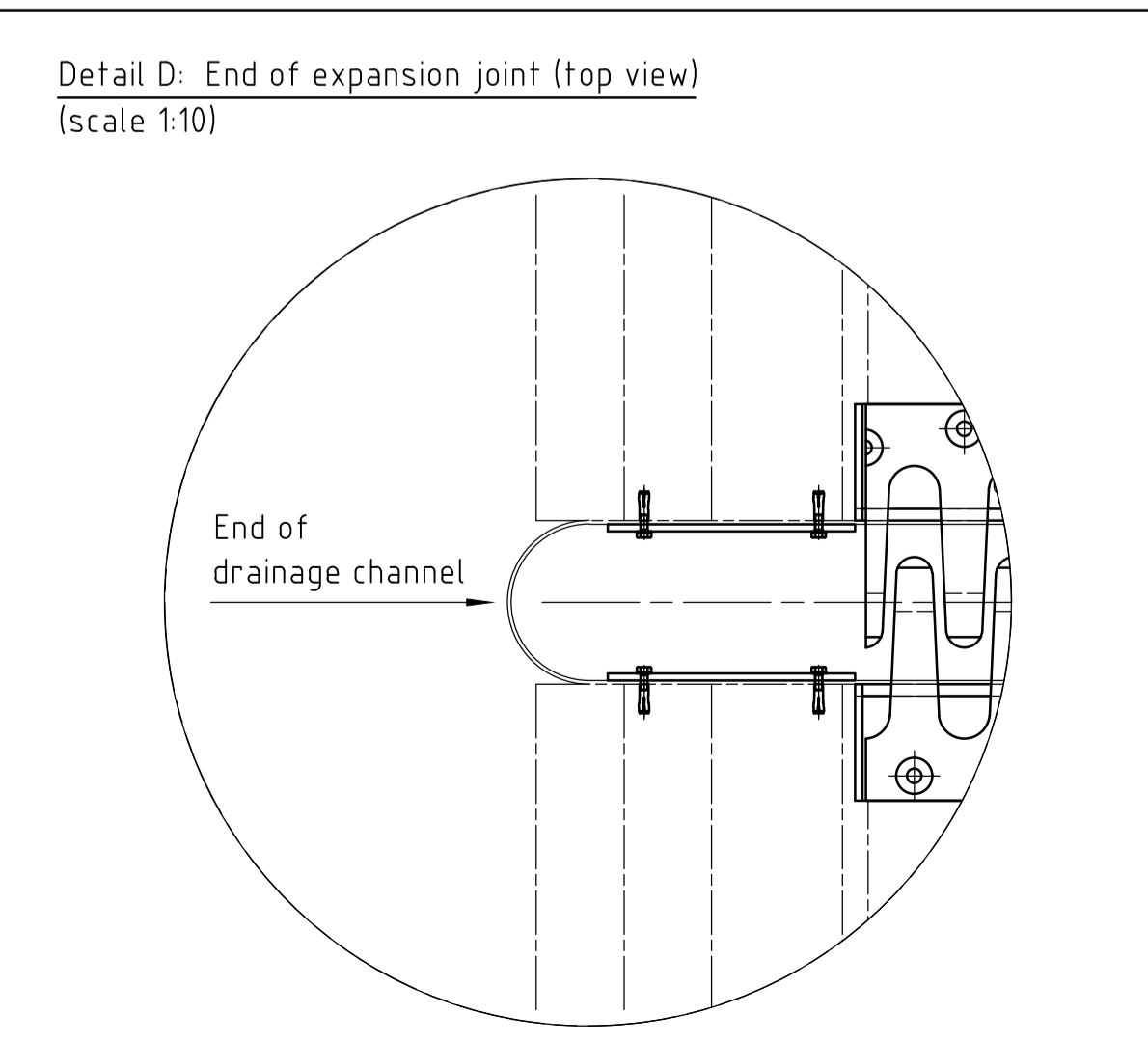
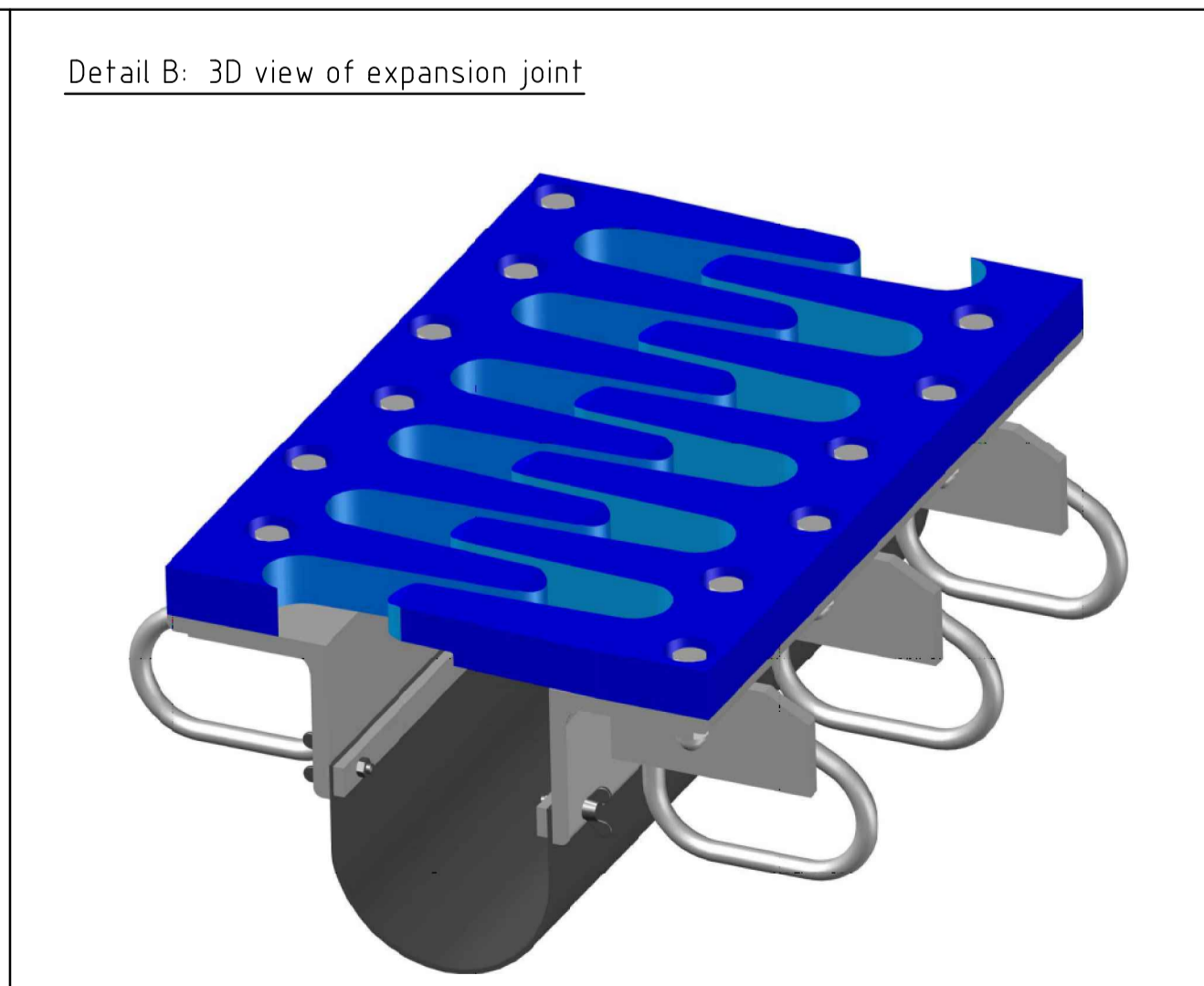
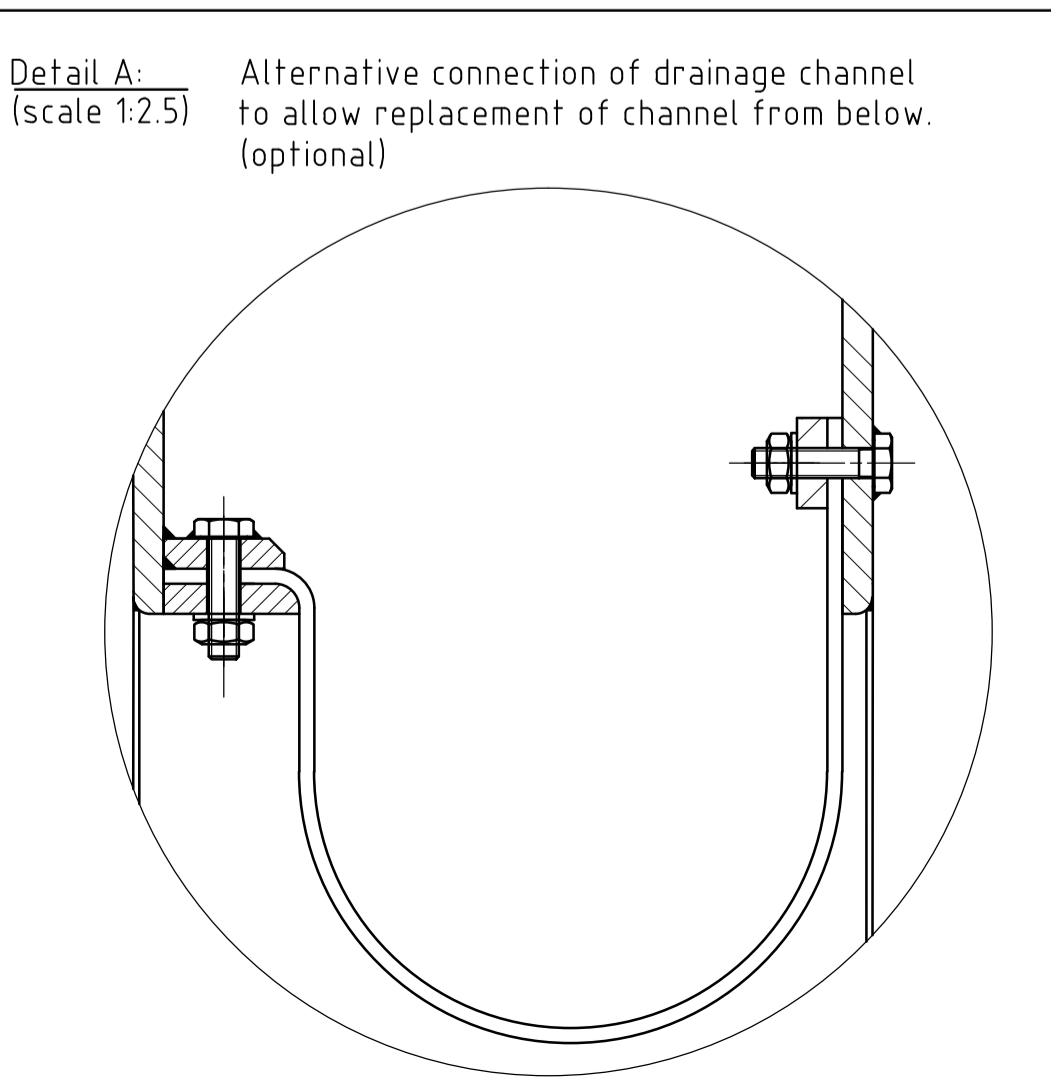

1	Carriageway anchor	255x200	5	S235JRG2	
1	Drainage channel	t=5	4	EPDM	
1	Edge beam	L 160x160x16	3	S235JG3	
1	Bolt	M20x70	2	8.8 hdg	
1	Finger plate	335x50x818	1	S355JG3	
ANZ.		BENENNUNG	DIMENSIONEN	POS.	MATERIAL
00	04.12.2009	Tender Drawing		LY	BU
Revision	Date	Description	Prepared	Reviewed	GM
				Article-No.	
SOLISTRASSE 68 8180 BULACH-SWITZERLAND TEL. +41-44-872 40 50 / FAX +41-44-872 40 59 mageba@mageba.ch - www.mageba.ch				General Tolerances according ISO 2768-	
Client:				Scale:	Weight:
Project:				1:33,20,10,7,5,2,5	263 kg/m
Structural Member: TENSA®FINGER RSFD-B 250			Location:	P-No:	Sheet-No:
The copyright on these drawings and all attachments, which have been entrusted personally to the receiver, belongs to mageba at all times. Without the express written permission of mageba the drawings must not be passed on or made accessible to any third parties. To guarantee the traceability of these drawings in accordance with ISO 9001, any electronic transmission shall be in PDF format only.					Drawing-No: Tensa Finger RSFD B 250-A1 Tender drawing