



Structural Bearings

Infrastructure | Buildings | Industrial structures

mageba structural bearings – mastering loads and movements



Glattalbahn Viaduct, Switzerland

RESTON® POT Bearings

well-proven, versatile, durable



mageba



Design and Types

Principle

mageba RESTON®POT bearings ensure the controlled transfer of loads between a structure's superstructure and its substructure. They also accommodate rotations about any axis and – where appropriate – movements of the superstructure. RESTON®POT bearings are generally suitable for use in any type of structure, and can be subjected to low or high loading and frequent movements and rotations.

mageba RESTON®POT bearings are designed and manufactured, per customer requirements, in accordance with relevant standards such as EN 1337, AASHTO, BS 5400, AS 5100, BRO or IRC:83.

Components

RESTON®POT bearings consist primarily of a steel pot ① with a lid ②, inside of which is placed an elastomeric pad ③. Under high pressure, the elastomeric pad behaves like a fluid, and allows rotations of the lid and thus of the superstructure to which it is connected.

Depending on whether the pot bearing is fixed, guided sliding or free sliding, it must resist some combination of vertical and horizontal loads, and perhaps also allow movements along one or all horizontal axes.

In the case of guided sliding and free sliding pot bearings, the upper surface of the lid features a sliding surface of PTFE ④. Together with the sliding plate ⑤ above it, this accommodates longitudinal and/or transverse sliding movements of the superstructure. To reduce frictional resistance and thus horizontal forces to a minimum, the lower surface of the sliding plate features a polished stainless steel sheet. In the case of bearings which should allow movement along one axis only, the direction of movement is controlled by central or external guide bars ⑥. The sliding surface should be protected from dust and debris by a rubber apron, which can be easily removed for inspections. Alternatively, a horizontal protective cover (concertina type with folding sheet) can be used.

The bearing is connected to the superstructure and the substructure by means of anchor dowels ⑦ or threaded sleeves (depending on design), or alternatively by means of separate anchor plates with shear studs.

Sliding bearings, whether accommodating movements in one direction only or in all directions, can also be equipped, if desired, with external movement scales. These indicate the horizontal movement of the bearing, and thus also that of the superstructure.

Types

RESTON®POT bearings are designated TF, TE or TA depending on their ability to accommodate sliding movements:

- TF: "Fixed" – The bearing resists horizontal forces in every direction, allowing no sliding movements
- TE: "Guided sliding" – The bearing allows sliding movements along one horizontal axis, and resists forces in the perpendicular direction
- TA: "Free sliding" – The bearing allows horizontal sliding movements in all directions, transmitting no external horizontal forces

Materials

The following high-quality materials are used in the manufacture of RESTON®POT bearings:

- Steel parts of grade S355 steel
- Elastomeric pad of natural rubber
- Sealing chain of POM
- Certified PTFE with grease dimples
- Certified silicone grease as lubricant
- Sliding sheet of polished, certified austenitic stainless steel (grade 1.4404)
- Sliding strips of 3-layer CMI material (DUB)
- Corrosion protection according to environmental conditions and customer requirements

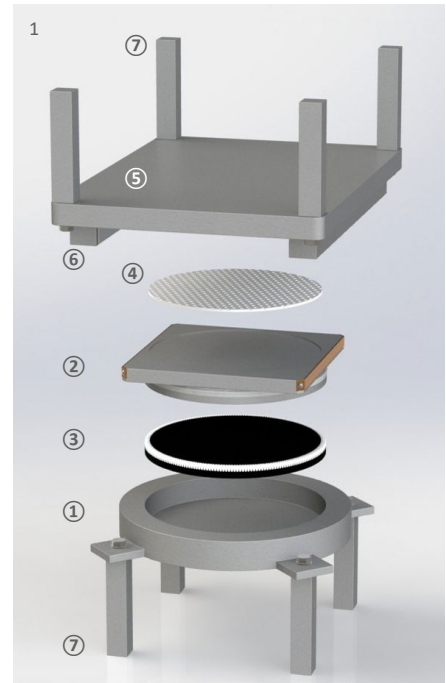

- 1 Build-up of a TE bearing featuring external guide bars
- 2 Installed TA bearing showing movement scale
- 3 Installed TA and TF bearings with anchor plates

Properties and Installation

Anchoring

Depending on design, bearings are connected to the superstructure and substructure by means of anchor dowels or threaded sockets, or by anchor plates with shear studs. Anchor dowels are suitable for the transmission of horizontal forces in the case of guided sliding (TE) and fixed (TF) bearings. Threaded sockets are suitable for free sliding (TA) bearings without anchor plates.

The use of anchor plates simplifies future bearing replacement. The number of shear studs on each anchor plate depends on static design requirements. Mixed designs, with anchor plates only above or below, or anchor plate strips, are also possible.

Sealing Chain

The heart of a RESTON®POT bearing is its elastomeric pad. To ensure that it functions properly and reliably, a sealing element at the gap between the bearing's pot and lid is required. For this purpose, mageda uses a POM sealing chain. In contrast to common brass seals, which simply rest on top of the elastomeric pad, the POM sealing chain is vulcanized into the pad, becoming an integral part of it. The potentially serious consequences of poorly placed sealing rings are thus avoided. The POM sealing chain offers the following advantages:

- Secure anchoring in the elastomeric pad
- Hard, highly wear-resistant plastic (POM)
- Individual links which can freely adapt to any deformations

Sliding Materials

For sliding bearings, mageda uses only PTFE of certified bridge bearing quality. The sliding surfaces feature grease dimples to enable grease to be stored. Certified silicone grease, which maintains its consistency and remains effective even at $-31\text{ }^{\circ}\text{F}$ ($-35\text{ }^{\circ}\text{C}$), is used. To keep frictional resistance as low as possible, the lower surface of the sliding plate features a polished stainless steel sheet.

Installation

RESTON®POT bearings must be handled with proper care during unloading and installation. Sliding surfaces, movement indicators and corrosion protection are particularly susceptible to damage and must be protected accordingly.

Bearings are pre-assembled in the factory, but anchor dowels and threaded sockets are generally delivered separately in order to optimize volume for transport. The bearing's pot, lid and sliding plate are bolted together for transport by means of temporary fittings.

- **Pre-setting:** The exact pre-setting values must be made known before fabrication begins, because pre-setting always takes place in the factory. Only trained experts may adjust the pre-setting on site.
- **Positioning:** The bearing location plan is the key element in the correct installation of the bearings. The structure's axes are marked on the bearings by grooves. This enables the bearings to be positioned precisely. The height is adjusted and horizontalness ensured by means of regulating screws. The reference point for the installation height is the middle of the cover or sliding plate.
- **Fixing:** After positioning, the anchor recesses (if any) are concreted. The subsequently placed mortar bed should not be more than 2 inches (50 mm) thick; the use of mortar which is able to flow beneath the bearing is recommended.
- **Taking into service:** The bearing must be able to move freely as soon as it is connected to both superstructure and substructure. This requires the temporary transport fittings to be cut and removed.

- 1 A TE bearing with anchor plates
- 2 POM sealing chain
- 3 A TE bearing with removable rubber dust protection apron
- 4 Optional console for 3-point levelling surface





Quality & Support

Quality

Over the past five decades, mageba has supplied over 50,000 structural bearings for projects all around the world. The quality and durability of mageba bearings is thus ensured not only by their well-proven product properties, but also by the extensive experience of our personnel.

mageba has a process-orientated quality system. In addition, its quality is regularly inspected by independent testing institutes. mageba factories are AISC certified for Major Bridges (CPT, STD, SPE) and also maintain AWS certifications for D1.1 and D1.5.

CE Conformity

mageba RESTON®POT bearings are designed and manufactured in accordance with "AASHTO LRFD Bridge Construction Specifications".

Alternatively, RESTON®POT bearings can also be designed and manufactured in accordance with European Standard EN 1337 and the product specific European approval (ETA-11/0453). Bearings are then marked with the CE mark of conformity, which confirms that they satisfy all requirements of this standard, without exception.

All necessary type testing performed on RESTON®POT devices are carried out at an independent testing facility and fully supervised by a certified body.

Optional Features

Depending on customer and national requirements, RESTON®POT bearings can additionally be equipped with the following features:

- 3-point leveling surface for precise leveling of the bearing
- Folding sheet as horizontal dust protection for the sliding surface instead of a rubber apron

Special Solutions

For special requirements, mageba offers the following bearing variations:

- **RESTON®ILM** Incremental Launch Method bearings: Facilitating construction of the bridge by the incremental launch method, and also serving as permanent bearings following completion of construction
- **RESTON®POT LIFT-CONTROL** lifting and measuring bearings: Provide permanent electronic monitoring of structural loads and, if required, can be used to lift the bridge
- **RESTON®POT UPLIFT** pressure/tension bearings: Allow temporary load reversal by preventing uplift

Offers

Quotations are provided on the basis of the types and numbers of bearing required. If desired, mageba can determine the types of bearing required, if provided with the following information:

- Maximum, minimum and permanent vertical loads and corresponding horizontal loads (ULS)
- Displacements and rotations in the structure's longitudinal and transverse directions
- General information about the structure (concrete strength, available space for bearings, etc.)

Support

Our experienced product specialists are always ready to provide you with further information and to advise you in selecting the optimal solution for your project.

You can also find further product information, including data sheets with standard bearing dimensions and reference lists, at mageba-group.com.

Project References – RESTON®POT Bearings



Storebaelt West Bridge (DK)



Pont sur le Buron (CH)



Pont de la Poya (CH)



Øresund Bridge (DK/SE)



Vasco da Gama Bridge (PT)



Conference Centre (HK)

mageba Structural Bearings



Spherical Bearings



Deformation Bearings



Lifting/Measuring Bearing



ILM Bearing



engineering connections®